

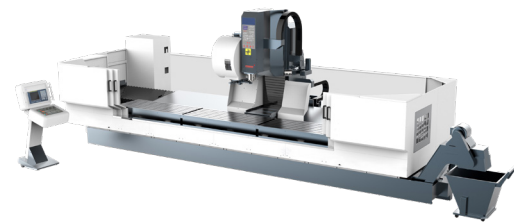

CNC-FAHRSTÄNDER-BEARBEITUNGSZENTRUM  
CNC-POMIČNI STEBRNI OBDELOVALNI CENTRI



Tip	$\begin{matrix} z \\ x \quad y \end{matrix}$ mm		min <sup>-1</sup>
BFM 580x2500	2.500x580x450	24	10.000
BFM 580x3000	3.000x580x450	24	10.000
BFM 580x4500	4.500x580x450	24	10.000
BFM 580x6500	6.500x580x450	24	10.000
BFM 580x8500	8.500x580x450	24	10.000

CNC-PORTAL-BEARBEITUNGSZENTRUM  
CNC-PORTALNI OBDELOVALNI CENTRI



Tip	$\begin{matrix} z \\ x \quad y \end{matrix}$ mm		min <sup>-1</sup>
WPC 2013/2513	2.000-2.500x 1.300x800/900	24	6.000
WPC 2018/ 3018/4018	2.000-4.000x 1.800x900	24	6.000
WPC 3022/ 4022/5022/6022	3.200-6.200x 2.200x1.000	24	6.000



CNC-5-ACHS-BEARBEITUNGSZENTREN  
CNC- 5 OSNI OBDELOVALNI CENTRI



Tip	$\begin{matrix} z \\ x \quad y \end{matrix}$ mm		min <sup>-1</sup>
WMC 5A 630	650x450x475	30	18.000
WMC 1100B	1.100x600x830	30	8.000-10.000
WFS 2000 5AX/ WFS L 2000 5AX	2.000x 610/800x700	30	12.000
WFS 3000 5AX/ WFS L 3000 5AX	3.000x 610/800x700	30	12.000
WFS 4000 5AX/ WFS L 4000 5AX	4.000x 610/800x700	30	12.000
WFS 5000 5AX/ WFS L 5000 5AX	5.000x 610/800x700	30	12.000

*Mi smo Wagner!*



CNC-FLACHSCHLEIFMASCHINEN  
CNC-BRUSILNI STROJI ZA PLOSKOVNO BRUŠENJE



Tip	$\longleftrightarrow$ mm	$\updownarrow$ mm	min <sup>-1</sup>
FSG 3A 818	480	220	2.850
FSG 3A 1224	630	355	1.450
FSG 1224 AD IV	650	295	500-2.100
FSG 1632 AD IV	850	395	500-2.100
FSG 1640 AD IV	1.050	395	500-2.100
FSG 2048/2064 AD IV	1.300/1.700	560	500-2.200
FSG 2448/2464/ 2480 AD IV	1.300/1.700/ 2.100	685	500-2.200
FSG 1224 AF	305	610	500-2.200
FSG 1640 AF	405	1.015	500-2.200



CNC-RUNDSCHLEIFMASCHINEN  
CNC-BRUSILNI STROJI ZA OKROGLO BRUŠENJE

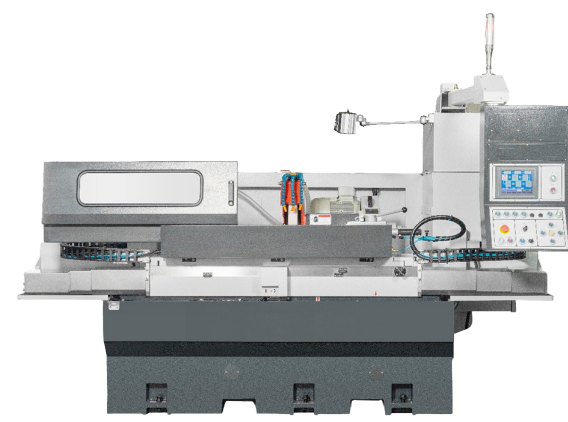

Tip	$\updownarrow$ mm	$\longleftrightarrow$ mm	min <sup>-1</sup>
WCG 2550 NC	500	250	2.000
WCG 3260 NC- WCG 32200 NC	600-1.000	300	30-350
WCG 3860 NC- WCG 38200 NC	1.500-2.000	360	30-350
WCG 5060 NC- WCG 50200 NC	600-2.000	480	10-600
WCG 2550 CNC	500	250	10-600

*Mi smo Wagner!*



MASCHINEN WAGNER

Werkzeugmaschinen GmbH

Robert-Bosch-Str. 1  
77871 Renchen

Tel.: +49 (0) 78 43 700 0  
Fax: +49 (0) 78 43 15 10

[www.wagner-maschinen.de](http://www.wagner-maschinen.de)  
[vertrieb@wagner-maschinen.de](mailto:vertrieb@wagner-maschinen.de)



AUS DEM SCHWARZWALD SEIT 1966



DREHEN  
FRÄSEN  
SCHLEIFEN  
BOHREN

STRUŽENJE  
FREZANJE  
BRUŠENJE  
VRTANJE

*Mechanik mit Herzblut!*

Vaš kontakt: Milan Čivre  
Telefon: + 386 (0) 40 688 280  
[mcivre@wagner-maschinen.de](mailto:mcivre@wagner-maschinen.de)



KONVENTIONELLE DREHMASCHINEN  
KONVENCIONALNE STRUŽNICE



Tip	$\varnothing$ mm	mm	$\varnothing$ min <sup>-1</sup> , mm
DLC 180	360/215	1.000	38/2.000
DLC 230	460/290	1.000/1.500	80/1.800
DLC 330	660/420	1.500/3.000	105/1.600
WDR 205/VS	410/230	1.100-3.100	63/2.000
WDR 255/VS	510/320	1.100-3.100	80/1.500
WDR 330/VS	660/410	1.000-6.000	104/1.250
WDR 380/VS	760/510	1.000-6.000	104/1.250
WDR 440	880/640	1.100-8.000	105/1.000
WDR 490	980/740	1.100-8.000	105/800



CNC-FLACHBETT-DREHMASCHINEN  
CNC STRUŽNICE Z RAVNO POSTELJO



Tip	$\varnothing$ mm	mm	$\varnothing$ min <sup>-1</sup> , mm
WDE 500	500/280	1.500	82/2.200
WDC 390	390/240	1.250	54/3.500
WDC 460	460/295	1.250	54/3.500
WDC 560	560/390	1.000/1.500/ 2.000/3.000	80/2.400
WDC 660	660/460	1.500/2.000/ 3.000/4.000	105/2.000
WDC 760	760/560	1.500-6.000	105/2.000
WDC 810	800/610	1.500-6.000	104/2.000
WDR 1200	650/1.290	1.500-5.000	130 / 500



CNC-SCHRÄGBETT-DREHMASCHINEN  
CNC STRUŽNICE S POŠEVNO POSTELJO



Tip	$\varnothing$ mm	mm	$\varnothing$ min <sup>-1</sup> , mm
WDS 570/A/AY	570/300	453/758	65/4.500
WDS 650/A/AY	650/400	600/550	87/4.000
WDS 680/A/AY	680/465	1.600/2.300	87/4.000

Obiščite tudi našo  
internetno stran



KONVENTIONELLE  
FRÄSMASCHINEN  
KONVENCIONALNI  
FREZALNI STROJI



Tip	$\begin{matrix} z \\ x \quad y \end{matrix}$ mm	mm	min <sup>-1</sup>
MFT 1370	1.000x380x400	1.370x320	43-3.225
BVT 1270 2VS	1.000x480x590	1.270x400	70-3.800
WBK 1300	1.300x460x770	1.500x400	70-3.800
WBK 1600	1.600x800x630	1.900x700	60-3.000



Tip	$\begin{matrix} z \\ x \quad y \end{matrix}$ mm	mm	min <sup>-1</sup>
FCD 400-600	405-600x 305-450x400-450	890x225	40-2.000
FCD 500	500x400x400	890x225	40-2.000
FCD 600	600x450x450	890x225	40-2.000
FCQ 1370x320	1.000x380x400	1.370x320	35-1.660
FCQ 1600x360	1.300x320x450	1.600x360	60-1.800



CNC FRÄS-  
MASCHINEN  
CNC FREZALNI  
STROJI



Tip	$\begin{matrix} z \\ x \quad y \end{matrix}$ mm	mm	min <sup>-1</sup>
WBE 1000S	1.000x420x580	1.270x400	4.200
WBE 1300S	1.300x500x580	1.500x400	4.200



SÄULEN- UND RADIAL-  
BOHRMASCHINEN  
STEBRNI IN RADILANI  
VRTALNI STROJI

Tip	mm	kW	min <sup>-1</sup>
WSB 40R	40	1,5	65-540/245-2.000
PRC 50x1.600	50	4	16/25-2.000
PRC 60x2.000	60	5,5	16/25-1.600
PRC 80x2.500	80	7,5	16/16-1.250
PRC 100x3.000	100	15	22/8-1.000
PRC 50 Touch	50	3,7	20-2.000



CNC-VERTIKAL-BAZ  
CNC VERTIKALNI OBDELOVALNI CENTRI



Tip	$\begin{matrix} z \\ x \quad y \end{matrix}$ mm	$\varnothing$	min <sup>-1</sup>
WME 1300	1.300x500x570	24	60-8.000
WME 1600	1.600x800x630	24/32/40	50-8.000
WME 2000-3000	2.000-3.000x 800x630	24/32/40	50-8.000
WMC 600L	600x400x450	24	SK40: 10.000/12.000
WMC 800L	800x500x550	24	SK40: 10.000/12.000
WMC 1100 C	1.100x600x600	30	1-10.000
WMC 1100	1.100x650x600	24	SK40: 1-8.000
WMC 1200/1400	1.200/1.400x 700x600	24	SK40: 1-8.000
WMC 1600/1800	1.600/1.800x 800x700	24	SK40: 40-8.000 SK50: 30-6.000
WMC 2000/2500	2.000/2.500x 1.000x800	24/32/40	SK40: 40-8.000 SK50: 30-6.000
WMC 3000	3.000x1.000x800	24/32/40	SK40: 40-8.000 SK50: 30-6.000